

AGILE PLUS S4 1150X525

THE INNOVATIVE PALLET TRUCK (1.200 KG)



AGILE

The innovative motorized pallet truck that combines electric and manual function for convenient usability. Compact, light, simple and easy to use, AGILE is the perfect pallet truck to minimize the operator effort, increasing efficiency and safety. Ideal in deliveries, supermarket, and retail shop, it can be used by everyone.



AGILE PLUS

The AGILE PLUS is equipped with a Li-ION powerful BATTERY 36V 12,8Ah and the ON BOARD COMPUTER with OLED display that supplies operator several information and the possibility to regulate the maximum travelling speed from 3,2 to 5,3 Km/h, adapting thus the operator experience to the specific application.



DOUBLE TRACTION WHEEL

The first pallet truck with two traction/steering wheels in the market. The big diameter (200mm) and tread (160mm) provide great stability without the needs of stabilizers. Non-marking rubbers grant great traction and comfortable usage on all applications.



LI-ION BATTERY

Long life 36V battery easy to remove for charging and continuous operation with the spare battery.

Two types of charger available (bench and wall mounted) with standard and fast charging time.



HIGH SPEED

The two motorwheels grant high performances and make the AGILE the fastest of the category. The AC technology and the soft non-marking rubbers make the AGILE an extremely quiet unit.



ALL FRAMES USE

Separate drive unit can be combined with frames of any size or metal (steel painted, galvanized, stainless steel) with a low impact cost and short delivery time. Please ask to your Pramac dealer for the combination requested.



ON-BOARD COMPUTER

Front OLED display with 6 selectable screens provides valuable info on truck activity and allows performance setup:

Pressing the central SCROLL button, operator can get information on:

- Battery status of charge (% of charge)
- Timers (total and partial in h)
- Odometer (total and partial in km)
- Speed setting (% of max speed)
- Diagnostic
- Error page



OPTIONS

- Quicklift hydraulic pump to lift the pallet in just two strokes
- Additional battery for continuous use
- Fast charging battery charger



Descriere

1.1 Producător			PR INDUSTRIAL
Stivuitoar			Manual
1.3 Comandă			ELECTRICĂ
1.4 Poziție operare			Pedestru
1.5 Capacitate maximă	Q	Kg	1200
1.6 Distanța la centrul de aplicare al sarcinii	c	mm	600
1.8 Sarcina de la osie la capătul furcilor	x	mm	932
1.9 Ampatament	y	mm	1192

Greutăți

2.1 Greutate de operare (acumulator inclus)		Kg	88
2.2 Sarcină osie, încărcare pe spate		Kg	891
2.2 Sarcină osie, încărcare pe față		Kg	395
2.3 Sarcină osie, liber față		Kg	59
2.3 Sarcină osie, liber spate		Kg	27

Cauciucuri/Șasiuri

3.1 Cauciucuri: roți direcție			CAUCIUC
3.1 Cauciucuri: roți stabilizatoare - Față			POLY.I.
3.1 Cauciucuri: transportoare cu role			NYLON
3.2 Mărime cauciuc: roți direcție - Lățime		mm	40
3.2 Mărime cauciuc: roți direcție - Diametru		mm	200
3.3 Mărime cauciuc: transportoare cu role - Diametru		mm	82
3.3 Mărime cauciuc: transportoare cu role - Lățime		mm	60
3.5 Dimensiune cauciuc: roti spate		nr	4
3.5 Dimensiune cauciuc: roti fata		nr	2x
3.6 Ecartament, față	b10	mm	162
3.7 Ecartament, spate	b11	mm	375

Dimensiuni

4.4 Înălțime stivuitoar	h3	mm	115
4.9 Înălțime manetă în poziția de deplasare, max	h14	mm	1185
4.9 Height of tiller in drive position min	h14	mm	710
4.15 Înălțime, coborât	h13	mm	85
4.19 Lungime globală	l1	mm	1600
4.20 Distanța până la suprafața frontală a furcilor	l2	mm	450
4.21 Lățime globală	b1	mm	525
4.22 Dimensiuni furcă - grosime	s	mm	55
4.22 Dimensiuni furcă - Lățime	e	mm	150
4.22 Dimensiuni furcă - Lungime	l	mm	1150
4.25 Distanța între furci	b5	mm	525
4.32 Gardă la sol și mijloc ampatament	m2	mm	30
4.34 Lățime culoar	Ast	mm	2063
4.35 Rază de virare	Wa	mm	1382

Performante

5.1 Viteză de deplasare cu incarcare	Km/h	4.2
5.1 Viteză de deplasare fără incarcare	Km/h	5.3
5.2 Viteză de ridicare, încărcat	strokes	12
5.2 Viteză de ridicare, descărcat	strokes	12
5.10 Frână de serviciu		REVERSE CURRENT BRAKING

Motoare electrice

8.4 Nivel sonor la nivelul urechii șoferului	dB(A)	60
--	-------	----

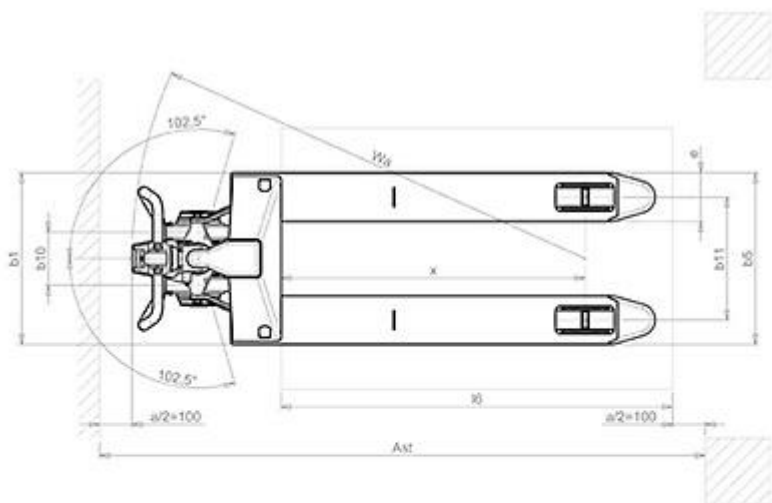
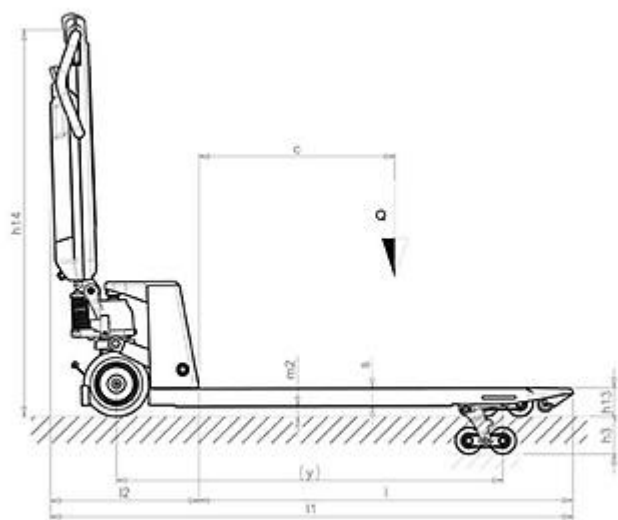

The information is aligned with the Data file at the time of download. Printed on 24/02/2020 (ID 10567)

©2019 | PR INDUSTRIAL s.r.l. | All rights reserved | Image shown may not reflect actual package. Specifications subject to change without notice

